

NOTE:- REFER DRWG. No.1118/10/032 SHEET-2 FOR TANK EQUIPMENT LIST

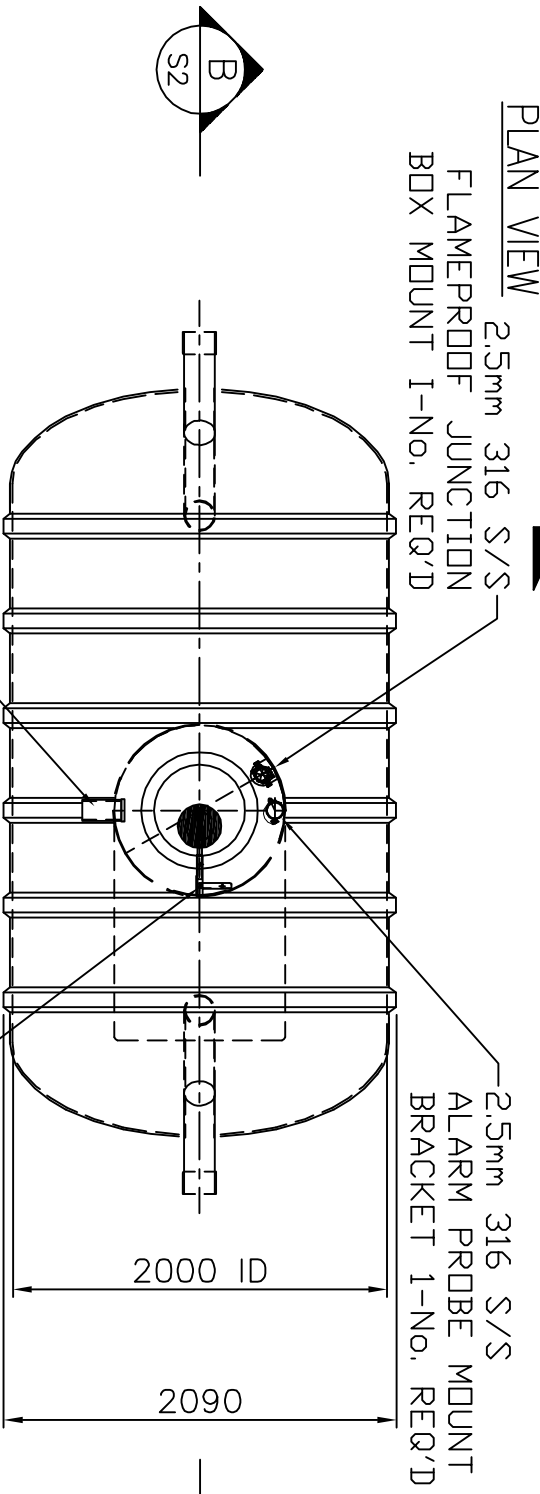
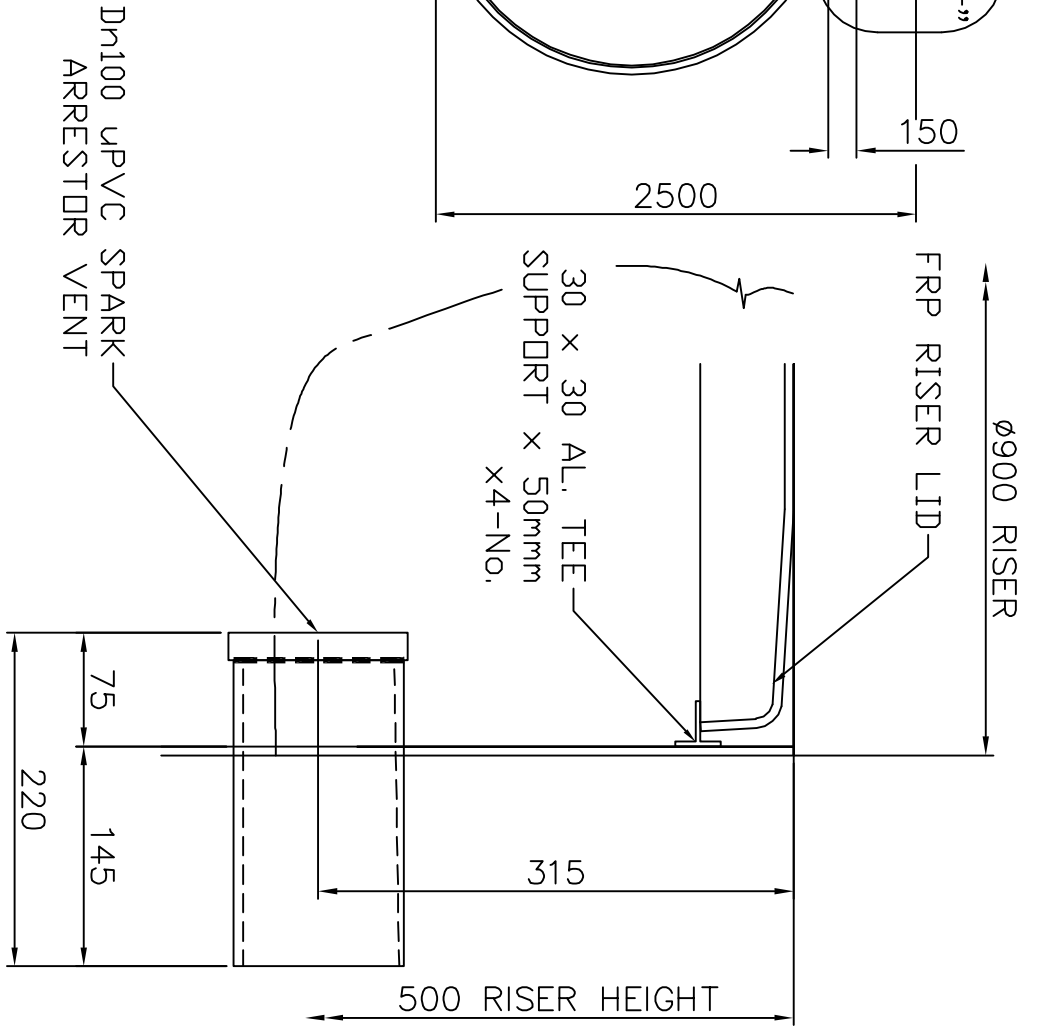

CLEARELO SEPARATOR SPECIFICATION
 Manufactured in accordance with: BS-EN-858-1 & BS-EN-858-2
 Type: Class-1 Full Retention
 Oil Storage Capacity: 400 Litres
 Oil Level Warning Device: Darcy Type-14300
 Depth of Oil Storage: 400mm
 Closure Device: Automatic 0.85 g/cm³
 Separator Volume: 20,000 Litres
 Nominal Size: 40NS
 Silt Storage: 200 Litres

- NOTES:-
- 1). INDICATES NO SKIN FITTINGS IN THIS AREA
 - 2). INDICATES HOLDOWN STRAP POSITIONS

Dn100 UPVC SPARK ARRESTOR VENT

2.5mm 316 S/S FLAMEPROOF JUNCTION BOX MOUNT 1-NO. REQ'D

2.5mm 316 S/S ALARM PROBE MOUNT BRACKET 1-NO. REQ'D

CUSTOMER		ENVIROTANK STANDARD	
REV	DESCRIPTION	DATE	SCALE
A	APPROVED FOR CONSTRUCTION	28.02.23	A3
DOC CHG NO	DRAWN DWB	CHECKED PQ	DATE
			28.02.23



Drwg.No.	1118/10/032	Rev.	A
Title:	ASSEMBLY DETAILS 900 RISER	Sheet:	1 OF 3
ECS10/20NS FORECOURT SEPARATOR			